



# SPINE ACCELEROMETER/GYRO ASSEMBLY MOUNT for Hybrid III 50M Model 78051-156Q Assembly

## INTRODUCTION

The Model 78051-156Q Assembly mount package is designed to allow measurements of thorax rotation. It enables the IES 3103 Gyro sensors to be mounted in the Hybrid III 50th spine box.

**NOTE:** To meet FMVSS-202a testing protocol, the sensor needs to have a CFC 600 response. This requires an IES 3103 Gyro sensor with the CFC 600 bandwidth option.

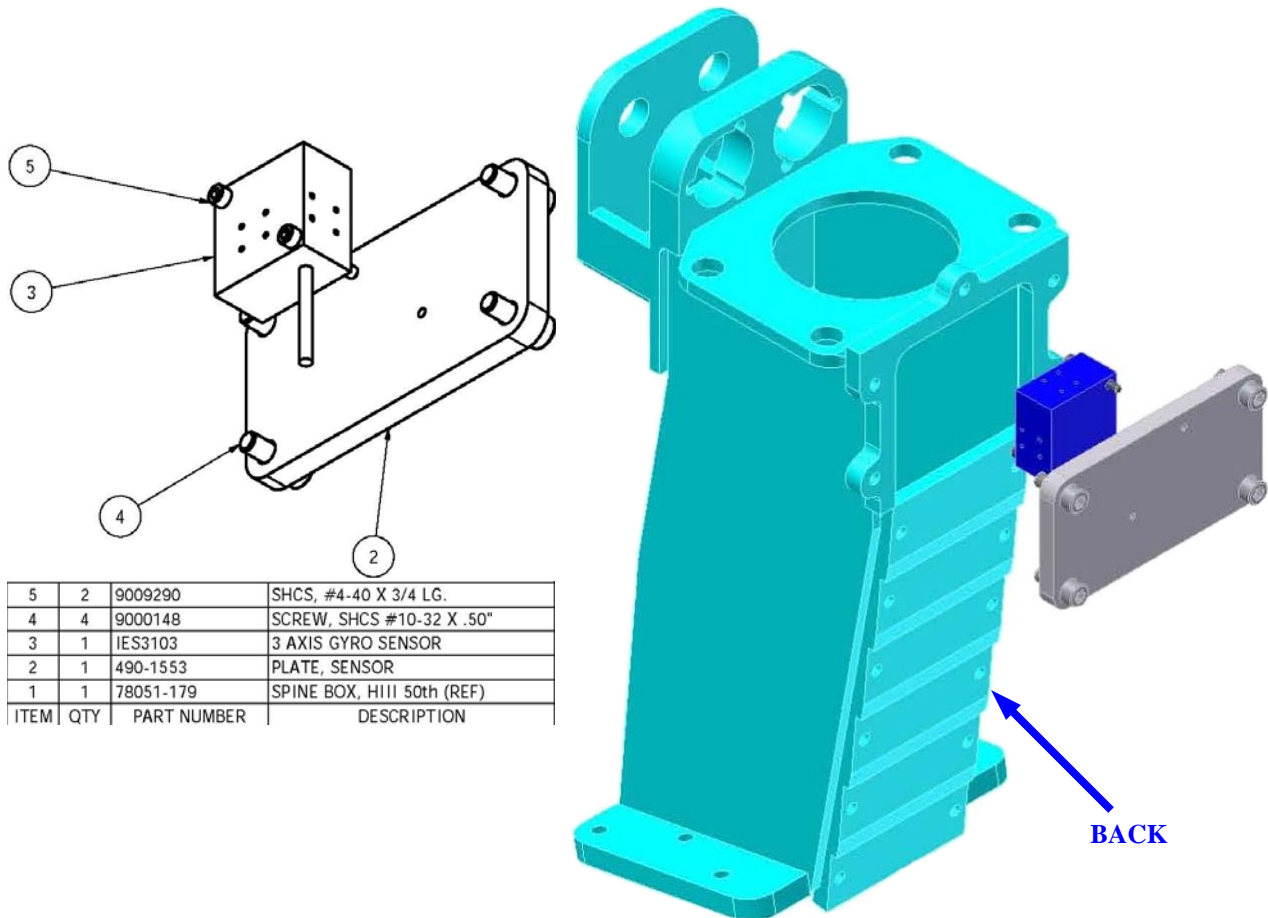

5	2	9009290	SHCS, #4-40 X 3/4 LG.
4	4	9000148	SCREW, SHCS #10-32 X .50"
3	1	IES3103	3 AXIS GYRO SENSOR
2	1	490-1553	PLATE, SENSOR
1	1	78051-179	SPINE BOX, HIII 50th (REF)
ITEM	QTY	PART NUMBER	DESCRIPTION