

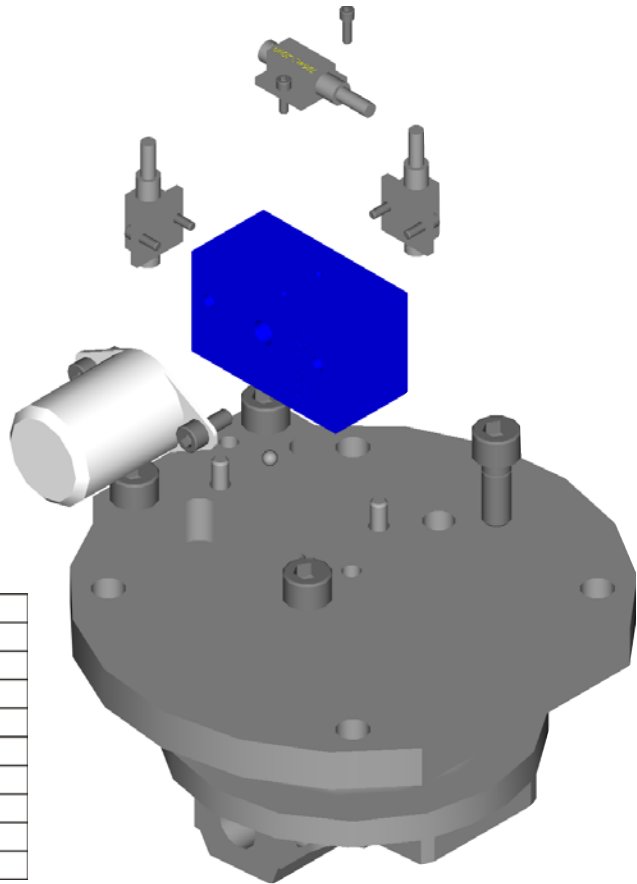

# HEAD ACCELEROMETER/GYRO ASSEMBLY MOUNT for Hybrid III 50M Model 78051-222R Assembly

## INTRODUCTION

The Model 78051-222R Assembly mount package is designed to allow measurements of head rotation in a Hybrid III 50th dummy for FMVSS 202a testing. It allows the ATA gyro sensors Models ARS-06 or ARS-06S to be mounted in the Hybrid III 50th head along with Endevco Model 7264-2000 or 7264C-2000 accelerometers or Measurement Specialties 64-2000 accelerometers. This mount system is designed to be a direct replacement for the standard Hybrid III 50th accelerometer mounts without re-ballasting of the head assembly.

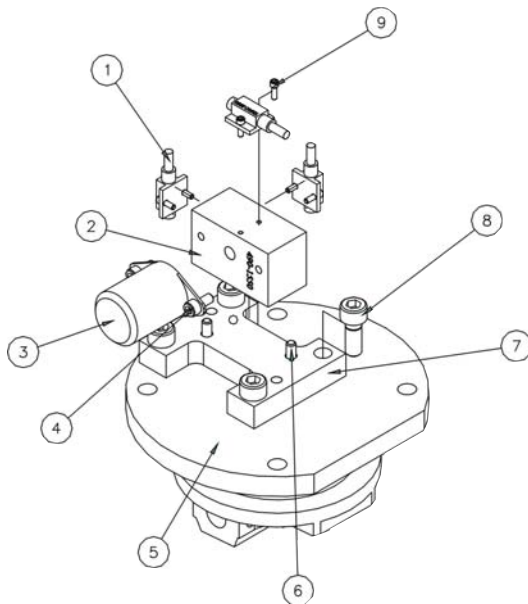

9	6	9005089	SCREW, SHCS #0-80 X 3/16
8	4	9000624	SCREW, SHCS 10-24 X 1/2" LONG
7	1	78051-222R	HEAD ACCELEROMETER MOUNT
6	2	9005058	SCREW, SHCS #4-40 X 3/8 LG.
5	1	78051-383X	NECK TRANSDUCER (REF)
4	2	9000528	SCREW, SHCS 4-40 x 1/4" LONG
3	1	ARS-06S	SENSOR, ANGULAR (REF)
2	1	490-1550	ACCELEROMETER MOUNTING BLOCK
1	3	7264C-2000	ACCELEROMETER (REF)
ITEM	QTY	NAME	DESCRIPTION

**NOTE:** This is a direct replacement for most Denton ATD Hybrid III 50th head accelerometer mounts. However, with older ASTC or Vector mounts or with competitors mounts, it is necessary to verify the mass of the head assembly. This mount assembly with all screws and sensors (without cables) has a mass of approximately .31 lb (141 g). To verify the mass of the head assembly, weigh the complete head assembly without the accelerometer mount, accelerometers or accelerometer mount screws. If the mass of that assembly is 9.69 +/- .08 lb (4.395 +/- .036 kg) then this mount package and sensors can be used without reballasting the head assembly. If the mass is not within this range, then the head assembly must be reballasted to use this mount package.